

DEW-POINT SWITCH

Pipe or Surface mount early-warning switch for dew-point or condensation monitoring

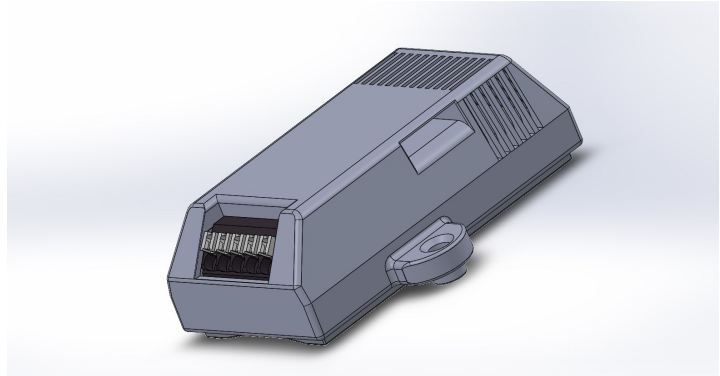

FEATURES

- Warns of dew-point before it is reached
- Compact and high-airflow design
- Ability to be mounted on pipe with equipped strap or directly to flat surface
- Coated electronics for dust and moisture protection
- Status LED indicator
- CE & RoHS compliant
- 5 year limited warranty
- Made in the USA

GENERAL INFORMATION

High quality dew point switch that sends early-warning signal before dew-point is reached which can be used to control condensation in critical environments. This is achieved by a quick and accurate response in monitoring relative humidity in combination with temperature.

Status LED light indicates condensation warning as 90% threshold is reached, as well as potential electronic failure.

The sturdy housing is well ventilated, coupled with a thermally conductive aluminum alloy contact surface contact making it suitable for a variety of applications. This product is designed for mounting directly on a pipe with a flexible strap included, or to a directly to a flat surface via the screw mounting holes.

SPECIFICATIONS

General:

Supply Voltage:	24V DC/AC $\pm 20\%$
Power Consumption:	10mA for 24VAC; 6mA for 24VDC
Operating Range:	0...+50°C / 32...+122°F ; 0...100%RH non-condensing
Enclosure Rating:	IP40
Enclosure Material:	PC/ABS UL 94 V-0, UV resistant injection-molded
Mounting:	surface, duct or strap
Connection:	5-pole spring connector, AWG 30—16 / 0.2—1.5mm ²
Weight:	~ 60 g
Storage Temperature	-20...+70 °C (-4...+158 °F)
Storage Humidity:	10...100% RH

SPECIFICATIONS CONT.

Switch-points:

RH > 90% ± 3%: Open on clamp DRY, Closed on clamp WET

RH < 90% ± 3%: Closed on clamp DRY, Open on clamp WET

Switching hysteresis: 5% RH
Switching voltage: 24V AC/DC
Switching current: 1 A span
Temp Response time: < 3 min
RH Response time: < 25 s

Status indication:

LED

ON: NO CONDENSATION
FLASHING: CONDENSATION DANGER
OFF: POWER OFF / FAILURE

Accessories:

2 mounting screws, TPE stretch tie-wrap

Approval:

CE & RoHS compliant

Warranty:

5 year limited warranty

ORDERING INFORMATION:

THHSDPS0

Tasseron Sensors Inc.
140 Choate Circle
Montoursville, PA 17754
Tel: +1 (570) 601-1971
Fax: +1 (570) 601-1972
Email: sales@tasseronusa.com

DIMENSIONS (in mm)

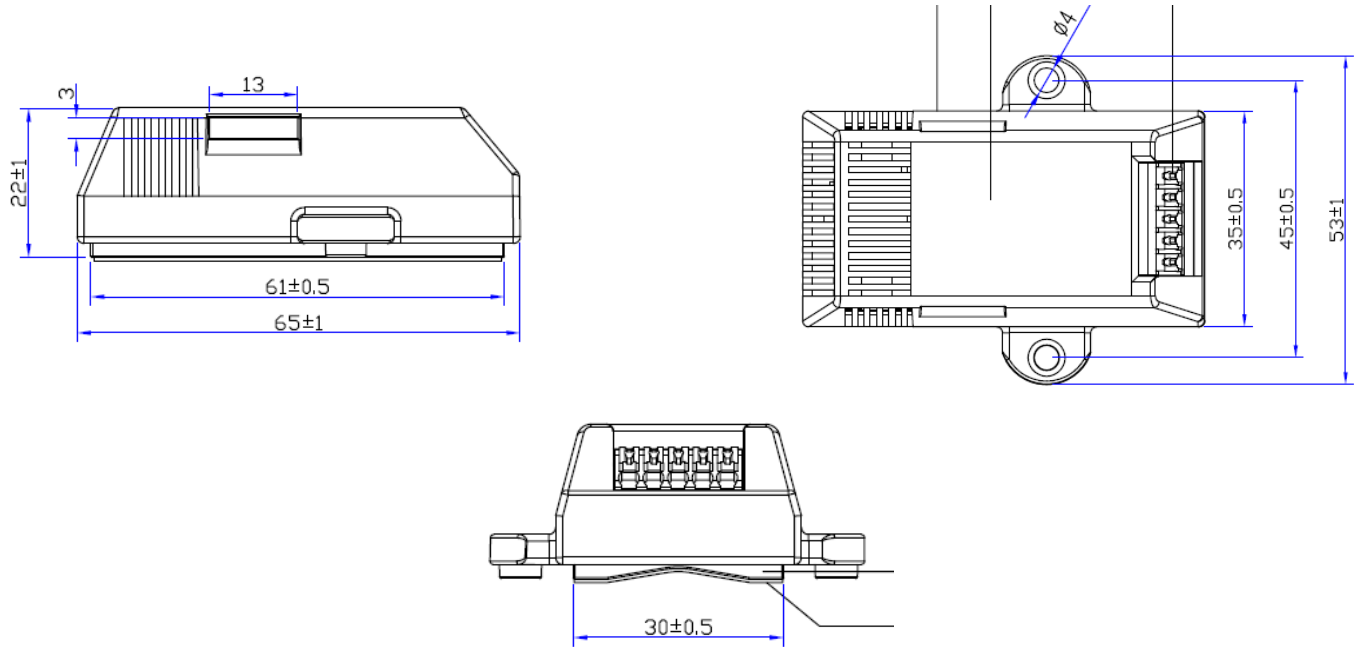

MOUNTING

Tasseron Sensors Inc.
140 Choate Circle
Montoursville, PA 17754
Tel: +1 (570) 601-1971
Fax: +1 (570) 601-1972
Email: sales@tasseronusa.com